

Unilift KP



Fig. 7 Unilift KP-S

Unilift KP is a single-stage, submersible, stainless steel drainage pump in compact design with hermetically sealed stator housing (wet runner).

The pump can be installed in a permanent installation or used as a portable pump. It may be operated fully or partially submerged.

The pump is suitable for:

- pumping in drain pits
- pumping of wastewater without discharge from toilets
- drainage of flooded cellars or buildings
- emptying of swimming pools, tanks and fountains
- applications within agriculture, horticulture, dairies, breweries and the process industry.

Versions

The Unilift KP pump series comes in these versions:

- KP-S with integrated, electronic sensor (automatic operation)
- KP-A with float switch (automatic operation)
- KP-M without level switch (manual operation).

It is possible to upgrade a Unilift KP-A and a Unilift KP-M, 220-240 V, 50 Hz, to a Unilift KP-S. Contact Grundfos.

Special features of Unilift KP-S

- Compact design - requires a minimum of space
- Automatically self-venting if air is trapped in impeller
- Protected against blocked impeller and dry-running
- Integrated, nanocoded, super-slip, electronic sensor
- Starts even with a 2 mm thick layer of dirt on the sensor plate.

Approvals

CE, LGA, VDE, GS, EMV, GOST, UL, CSA and C-TICK.

Pumped liquids

The pump is suitable for

- clean, non-aggressive water
- slightly dirty (grey) wastewater.

The open-impeller construction ensures the free passage of solids up to $\varnothing 10$ mm.

Functions

Unilift KP-S

Automatic start/stop operation by means of a sensor.

The pump starts:

- when the liquid level reaches the sensor plate
- when the pump is connected to the electricity supply
- when the sensor plate is touched with a finger.

The pump stops:

- when the pump starts to suck air (automatic stop)
- if the impeller is blocked.

Unilift KP-A

Automatic start/stop operation by means of a float switch.

Unilift KP-M

Manual operation by means of external start/stop.

Construction

The stainless steel pump sleeve is made in one piece with Rp 1¼ discharge port and insulating handle. Mains cable and float switch cable are combined in one vulcanized and water-tight plug, secured to the socket of the hermetically sealed stator housing.

Liquid enters the pump through the holes of the suction strainer. The holes of the strainer prevent the passage of large solids.

The sturdy impeller has single-curved vanes. The bevelled front edges prevent fibres from jamming the impeller.

The guide vanes of the pump housing guide the liquid, lifting sand grains into the liquid flow. This prevents sand from blocking the impeller.

Motor

The motor is a single- or three-phase, asynchronous canned motor with liquid-filled rotor chamber and water-lubricated bearings. The motor is cooled by the pumped liquid around the motor.

Enclosure class: IP 68

Insulation class: F.

The motor incorporates automatic overload protection. In case of overload, the motor stops automatically. When cooled, the motor restarts automatically.

Selection

The below overview is suitable for the selection of the correct size of Unilift KP pumps used in stationary applications.

The flow velocity through the discharge pipe must be minimum 0.7 m/s to ensure self-cleaning.

Example: A DN 32 discharge pipe with an inner diameter of 26 to 34 mm (depending on local standards) requires a minimum flow velocity of approximately 2.3 m³/h.

The overview below shows the maximum lengths of combined vertical and horizontal DN 32 discharge pipes.

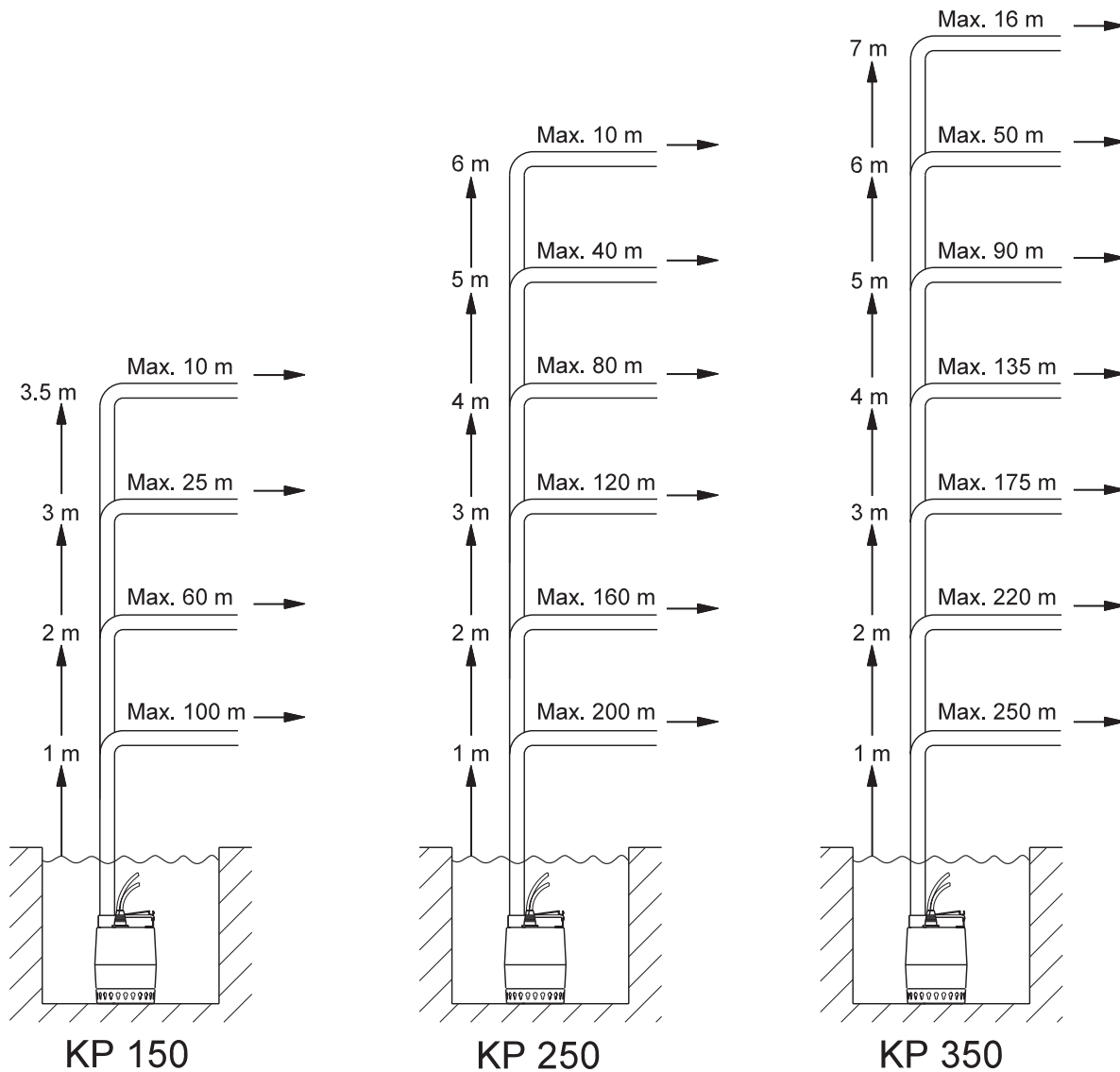

Fig. 8 Overview of maximum lengths of combined vertical and horizontal discharge pipes

The above overview is only intended as a guide. Grundfos is not liable for any faulty installations based on the overview.

Note: If the non-return valve is used, the pressure drop in the valve is 0.2 m head. The pressure drop is to be subtracted from the vertical pipe lengths.

The vertical height of the discharge pipe should be measured from the pump stop level.

TM03 1643 2505

Operating conditions

Installation depth:	Max. 10 metres below liquid level
Min. liquid temperature:	0°C
Max. liquid temperature at continuous operation:	50°C *

* At intervals of at least 30 minutes, the pump is allowed, however, to run at maximum +70°C for periods not exceeding 2 minutes.

During continuous operation, the suction strainer must always be completely covered by the liquid.

Installation

Unilift **KP-S** requires a minimum of space. If the pump is installed in a pit, the pit diameter must be minimum 200 mm to avoid too many starts and stops. Use the recommended dimensions in the table below.

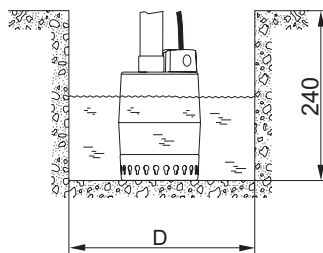

TM03 4674 2406

Fig. 9 Pit dimensions, Unilift KP-S

Pit diameter, D [mm]	200	250	300
Maximum inlet flow to the pit [m ³ /h]	0.3	0.7	1.3

If Unilift **KP-A** is installed in a pit, the minimum pit dimensions must be as shown in the figure below.

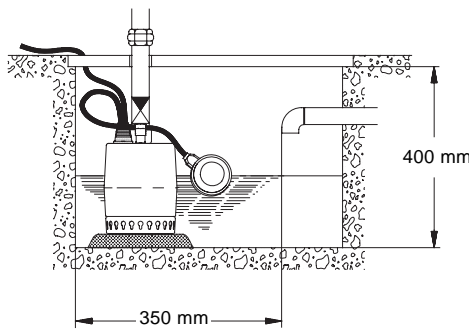

TM03 4445 2106

Fig. 10 Minimum pit dimensions, Unilift KP-A

Pump positioning

Unilift **KP-M** and Unilift **KP-A** can be used in the vertical position with the discharge port uppermost or in the horizontal or tilted position with the discharge port as the highest point of the pump.

Unilift **KP-S** must be used in the vertical position.

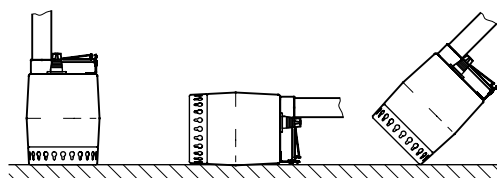

TM00 1548 0493

Fig. 11 Pump positions

Level switches

A level switch starts and stops the pump between two liquid levels. This type of installation requires a non-return valve in the discharge pipe or the pump. Unilift KP pumps are available with two different level switch types.

Unilift KP-S with electronic sensor

The sensor is integrated in the pump. Consequently, the difference in level between start and stop cannot be adjusted.

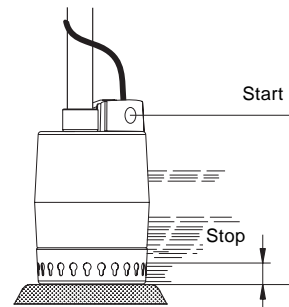

TM03 4446 2106

Fig. 12 Start-stop level, Unilift KP-S

Pump type	Start [mm]	Stop [mm]
Unilift KP-S 150		
Unilift KP-S 250	205	15
Unilift KP-S 350	215	15

Unilift KP-A with float switch

A clamp on the pump handle holds the float switch cable. The difference in level between start and stop can be adjusted by changing the free cable length between pump handle and float switch.

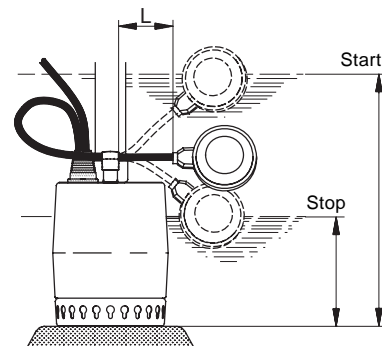

TM03 4446 2106

Fig. 13 Start/stop levels at min. and max. cable lengths, Unilift KP-A

Pump type	Cable length (L) min. 70 mm		Cable length (L) max. 150 mm	
	Start [mm]	Stop [mm]	Start [mm]	Stop [mm]
Unilift KP-A 150				
Unilift KP-A 250	290	140	335	100
Unilift KP-A 350	300	150	345	110

Performance curves

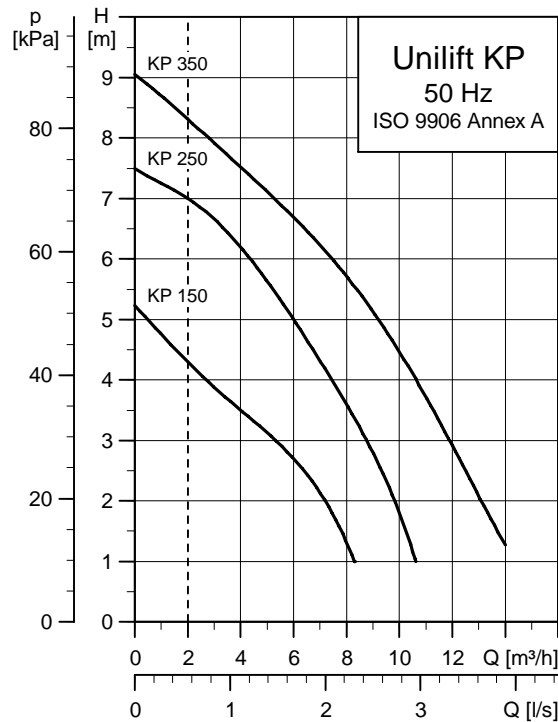

The broken line shows a minimum liquid velocity of 0.7 m/s with a DN 32 discharge pipe to DIN EN 12056.

TM03 1593 2505

Pump type	Supply voltage [V]	Power P_1 [W]	Current, I_n [A]	Power factor $\cos \varphi$	Speed [min^{-1}]	Capacitor μF
KP 150	1 x 220-230	300	1.3	0.99	2900	8
KP 150	1 x 230-240					
KP 250	1 x 220-230	480	2.3	0.97	2900	8
KP 250	1 x 230-240					
KP 250*	3 x 380-415	480 (415 V)	0.8			
KP 350	1 x 220-240	700	3.2	0.99	2900	8
KP 350*	3 x 380-400					

* Not available in the Unilift KP-S version.

Pump dimensions

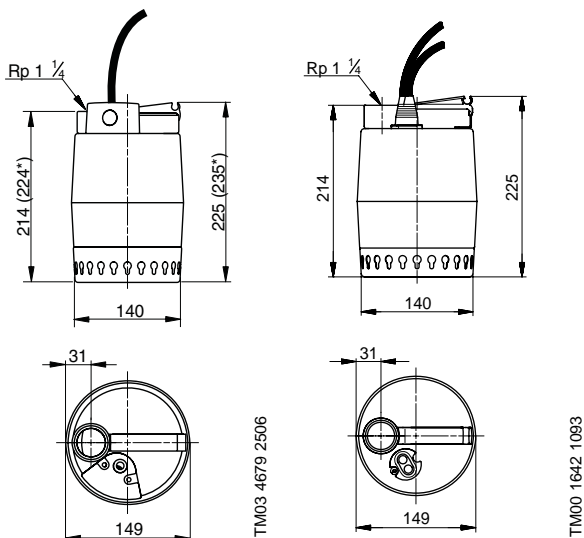
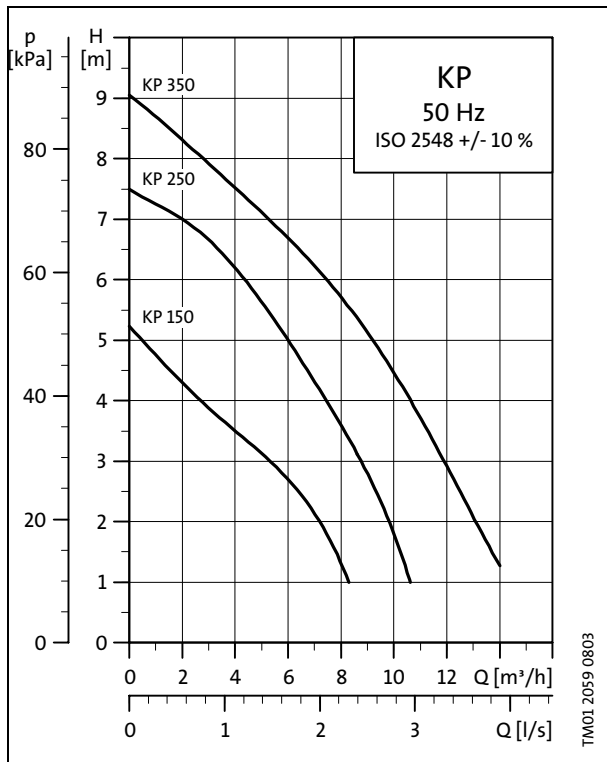

Fig. 14 Pump dimensions

* Unilift KP-350

Materials

Component	Material	DIN W.-Nr.	AISI
Pump sleeve	Stainless steel	1.4301	304
Pump housing	Stainless steel	1.4301	304
Suction strainer	Stainless steel	1.4301	304
Impeller	Stainless steel	1.4301	304
Shaft	Stainless steel	1.4057	431
Stator housing	Stainless steel	1.4301	304
Guide vanes	Stainless steel	1.4301	304
Bearings	Carbon		
O-rings	NBR		
Seal rings			
Cables	H07RN-F 3 G 1 H07RN-F 4 G 1		



Pump type	Voltage	P ₁ [W]	I _n [A]	Dimensions [mm]						Weight [kg]
				H	B1	B2	L1	L2	L3	
KP 150	1 x 220-230 V	300	1.3	225	149	31	350	400	70	6.3
KP 150	1 x 230-240 V	300	1.3	225	149	31	350	400	70	6.3
KP 250	1 x 220-230 V	480	2.3	225	149	31	350	400	70	7.2
KP 250	1 x 230-240 V	480	2.2	225	149	31	350	400	70	7.2
KP 250	3 x 380-415 V	480	0.8	225	149	31	350	400	70	7.2
KP 350	1 x 220-240 V	700	3.2	235	149	31	350	410	70	8.0
KP 350	3 x 380-400 V	700	1.3	235	149	31	350	410	70	8.0

With float switch

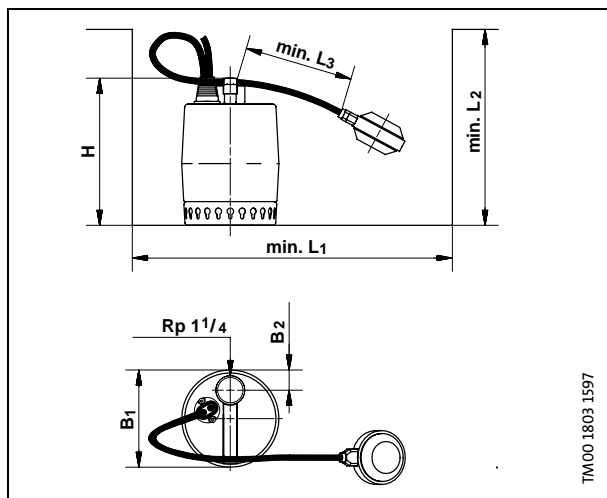

With vertical level switch

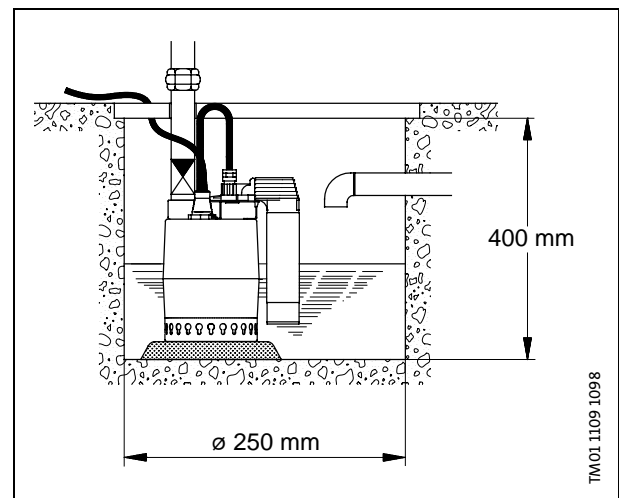

Installation

Pumps without level switch or with float switch can be used in vertical position with the discharge port uppermost or in horizontal or tilted position with the discharge port as the highest point of the pump.

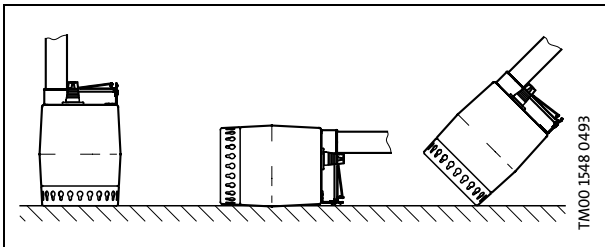

Pumps with vertical level switch must be used in vertical position.

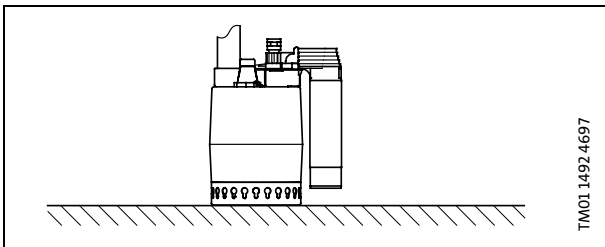

The KP pump is well suited for permanent installation.

Level switches

A level switch, which gives impulses to start/stop between two levels of liquid, is connected to pumps intended for automatic operation. This type of installation requires a non-return valve in the discharge pipe or in the pump. The pumps are available with two different types of level switches.

Min. liquid level: – manual operation: 14 mm.
– automatic operation: See below.

Pumps with float switch:

A clamp on the handle of the pump holds the cable of the level switch. The difference in level between start and stop can be adjusted by changing the free cable length between the handle of the pump and the level switch.

Dimensions for KP 350 are marked with "★".

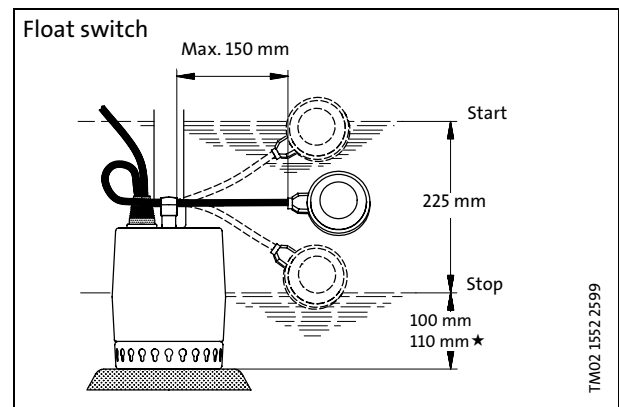

Pumps with vertical level switch:

For pumps with vertical level switch, the difference in level between start and stop is not adjustable.

Dimensions for KP 350 are marked with "★".

