



# Product Info Sheet

## TOPAZ INDUSTRO FLOAT VALVE



### Description

Topaz Industro Float Valves are designed to maintain water levels in applications requiring a valve with high mechanical strength and heat resistance, Industrial storage tanks and heated water cisterns. Some typical applications would be refilling cooling towers and storage tanks, High pressure cleaning and Car wash systems as well as many light industrial, Air conditioning and Irrigation installations.

### Applications

Maintaining Water Levels in:

- Car wash systems
- Water Storage Tanks
- Water Cisterns
- Air Conditioning Systems
- High Pressure Cleaning Systems
- Irrigation Applications

### Flow Graph

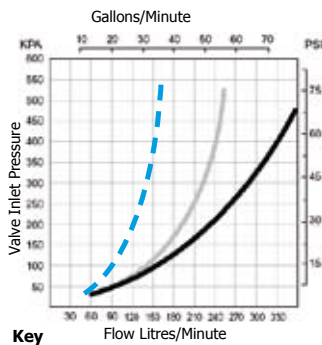

### Features

- High flow
- Compact robust construction
- Maximum water temperature 80°C / 176°F
- Made from approved materials
- Mounts horizontally or vertically
- Made from corrosion resistant materials
- Shuts down slowly to minimise water hammer
- 20 - 60mm (3/4" - 2 1/2") water level differential (increases as water inlet pressure increases)
- Pressure rating 0.3 - 7 Bar (5 - 100 PSI)
- Float position easily adjustable with no tools
- Valve has switch to lock it in off position
- Has port to connect Frostpro anti freeze device

### Mounting Positions

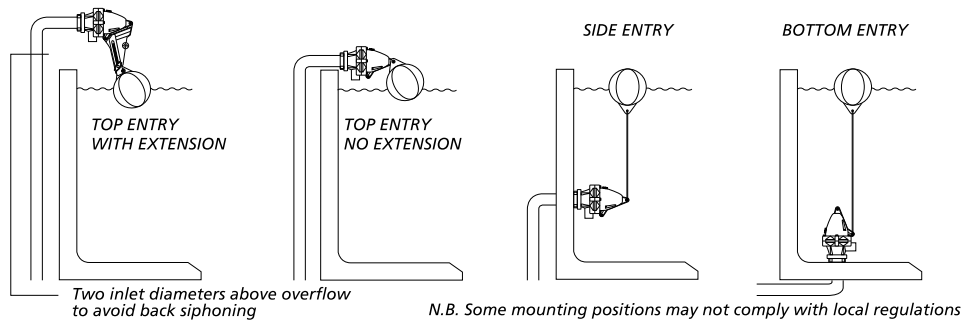

### Options

	BSP		NPT		
Inlet Size	3/4"	1"	3/4"	1"	Specifies this Thread size
Detach Base Short Tail		✓		✓	
Detach Base Long Tail	✓		✓		Standard Detach
<b>Long Tail:</b>	Supplied with backnut and seal washer 3/4" Long Tail: 38mm long.				
<b>Floats:</b>	125mm wide floats supplied standard. Note: Suitable for any mounting position				Standard
	70mm and 95mm floats optional Note: Suitable for top entry only.				Optional
					Optional
	125mm	70mm	95mm		

### TOPAZ INDUSTRO FLOAT VALVE SPECIFICATION

PRODUCT	CODE	INLET SIZE	CODE	OPTIONS	CODE
Topaz Industro Float Valve	TIV	3/4" bsp/npt	20	Detach Base	D
		1" bsp	25	Long Tail Base	LT
		1" npt	1"	70mm wide Float	F70
				95mm wide Float	F95

(e.g) A Topaz Industro Float Valve with: 3/4" bsp inlet thread, detach base, long tail thread has the following spec number: TPV 20 D LT

NOTE: If no options are specified the standard ones will be supplied

Note: Product may differ slightly from these specs due to ongoing product development.